

# Fibre TV Agreement

NBN Co Limited





NBN Co Limited

## Fibre TV Agreement

### Change Log

Version	Description	Effective Date
1.0	Issued on 4 December 2015	Execution Date
1.1	Amended agreement published 30 June 2017	Execution date of variation letter
1.2	Amended agreement issued with variation letter on 19 May 2017	Execution date of variation letter
1.3	Amended Term on 24 November 2020	Execution date of variation letter
1.4	Amended Term on 14 June 2022	Execution date of variation letter
1.5	Amended agreement to comply with unfair contract terms legislation and extension of Term	29 May 2024

### Copyright

This document is subject to copyright and must not be used except as permitted below or under the Copyright Act 1968 (Cth). You must not reproduce or publish this document in whole or in part for commercial gain without the prior written consent of NBN Co. You may reproduce and publish this document in whole or in part for educational or non-commercial purposes as approved by NBN Co in writing.

Copyright © 2024 NBN Co Limited. All rights reserved. Not for general distribution.

### Disclaimer

This document is provided for information purposes only. The recipient must not use this document other than with the consent of NBN Co and must make their own inquiries as to the currency, accuracy and completeness of this document and the information contained in it. The contents of this document should not be relied upon as representing NBN Co's final position on the subject matter of this document, except where stated otherwise. Any requirements of NBN Co or views expressed by NBN Co in this document may change as a consequence of NBN Co finalising formal technical specifications, or legislative and regulatory developments.

### Environment

NBN Co asks that you consider the environment before printing this document.



Fibre TV Agreement

**Parties**

1. nbn co limited (ABN 86 136 533 741) of Level 13, 100 Mount Street, North Sydney NSW 2060 (**nbn**)
2. [**Insert full legal name of customer**] (ABN [**insert ABN**]) of [**insert registered address of customer**] (**Customer**)

**Background**

- A. This Agreement sets out the terms on which:
  - Customer may order Fibre TV from **nbn** in respect of Eligible Estates, and **nbn** will supply Fibre TV to Customer over Fibre TV Infrastructure; and
  - Customer will acquire Fibre TV from **nbn** in respect of Eligible Estates and use Fibre TV as an input to Customer’s supply of Customer Content to Premises in those Eligible Estates.
- B. The parties recognise the importance of ensuring Premises in Eligible Estates have continued supply of content and acknowledge the need to cooperate to ensure continuity in the event of early termination of this Agreement by either party
- C. Customer acknowledges if nbn terminates this Agreement early for a material breach or Customer seeks to terminate this Agreement early, Customer will be required to provide nbn with a proposal for the continued supply of content to Premises at the affected Eligible Estates (in accordance with clause 22).

**Agreement**

**1 Product**

- 1.1 Fibre TV is a product comprising of the following elements in respect of an Eligible Estate to which **nbn** supplies Fibre TV to Customer:
  - (a) the grant by **nbn** to Customer of non-exclusive limited access to Fibre TV Infrastructure at locations specified by **nbn**; and
  - (b) the carriage by **nbn** of Customer Content injected by Customer into Fibre TV Infrastructure, in a single direction from the NNI-RFo for that Eligible Estate to multiple UNI-RFe at that Eligible Estate.
- 1.2 Further details of Fibre TV are set out in Schedule 2 and Annexure 1.
- 1.3 **nbn** will grant facilities access to Customer to the extent exclusively required for Customer to acquire Fibre TV, under and subject to Schedule 3.
- 1.4 Customer must supply all network elements required for the supply of Customer Content

- except for the network elements set out in clauses 1.1 to 1.3.
- 1.5 Without limiting clause 1.4, Customer must supply all network elements:
    - (a) upstream of the NNI-RFo; and
    - (b) downstream of the UNI-RFe.
  - 1.6 Where **nbn** supplies Fibre TV to Customer in respect of an Eligible Estate, Customer may only use Fibre TV to supply Customer Content to Premises at that Eligible Estate and perform such other activities as are contemplated by this Agreement.
  - 1.7 Customer must self supply, or separately obtain from third parties, any facilities access required to perform its obligations under this Agreement except to the extent granted under Schedule 3.

**2 Preconditions to supply**

- 2.1 As a pre-condition to **nbn** supplying Fibre TV to Customer, Customer must participate in and successfully complete all on-boarding activities



and pass all capability and verification testing reasonably required by **nbn** from time to time, including to ensure:

- (a) the safety of Customer Equipment and Customer Platforms and their compatibility with the **nbn**<sup>®</sup> Network and **nbn**<sup>®</sup> Platform;
- (b) Customer's ability to supply Customer Content to Premises in relevant Eligible Estates; and
- (c) Customer's ability to perform its obligations under this Agreement, including in a manner that ensures the safety and operation of the **nbn**<sup>®</sup> Network and **nbn**<sup>®</sup> Platform.

2.2 Customer warrants to **nbn** that throughout the period in which **nbn** supplies Fibre TV to Customer, Customer:

- (a) is and will remain a Carrier, Carriage Service Provider, Content Service Provider and/or a Specified Utility engaging in a related Specified Activity; and
- (b) is of good financial standing and creditworthiness,

(the **Supply Conditions**).

2.3 **nbn** is not obliged to supply or continue to supply Fibre TV to Customer if Customer fails to:

- (a) comply with the Supply Conditions; or
- (b) supply the Customer Content in accordance with this Agreement in respect of any Eligible Estate.

2.4 Customer must notify **nbn** within 2 Business Days of the time Customer no longer complies with any Supply Condition.

### 3 Acceptance Tests

3.1 Customer must:

- (a) conduct Acceptance Tests prior to the installation and activation of any new form of Head-End Equipment or RF Converter which has not been previously tested and approved by **nbn**; and

- (b) rectify any matter which causes any Acceptance Tests to fail.

3.2 Prior to entering into any agreement or arrangement with any third party to supply Customer Content in respect of an Eligible Estate, Customer must obtain approval from **nbn** (such approval not to be unreasonably withheld) for:

- (a) the Customer Equipment which will be used in conjunction with Fibre TV Infrastructure to supply the Customer Content;
- (b) the Customer Content which will be supplied using Fibre TV; and
- (c) any other Customer commitment or obligation in such agreement or arrangement which relies on any supply by **nbn** under this Agreement.

### 4 Ordering

4.1 From time to time throughout the Term, **nbn** will make available to Customer a list of Eligible Estates in respect of which **nbn** has installed or plans to install Fibre TV Infrastructure.

4.2 Customer may place an order for Fibre TV in respect of any listed Eligible Estate by:

- (a) agreeing the location of an NNI-RFo in respect of the Eligible Estate with **nbn**; and
- (b) submitting a Delivery Plan to **nbn** (which includes the agreed location of the NNI-RFo and details of any facilities access which Customer requests from **nbn** under Schedule 3), using such means as may be specified by **nbn** from time to time.

4.3 A Delivery Plan submitted in accordance with this clause 4 constitutes an offer from Customer to acquire Fibre TV in respect of an identified Eligible Estate, which is capable of acceptance by **nbn**.

4.4 **nbn** will accept or reject an order for Fibre TV in respect of an Eligible Estate by written notice to Customer.

4.5 **nbn** may reject an order for Fibre TV in respect of an Eligible Estate:



- (a) if **nbn** determines, on reasonable grounds, that Customer:
  - i has failed to submit a valid Delivery Plan in respect of the order, including because a submitted Delivery Plan fails to comply with any part of this Agreement; or
  - ii has failed, or is reasonably likely to fail, to comply with any part of this Agreement or the Delivery Plan; or
- (b) if **nbn** declines, on reasonable grounds, to supply any facilities access that is requested in the Delivery Plan; or
- (c) in any other circumstances, if **nbn** determines that:
  - i it will be unable to supply the order; and
  - ii it is consistent with **nbn's** statutory obligations to supply Fibre TV.

4.6 If **nbn** accepts an order for Fibre TV in respect of an Eligible Estate, then:

- (a) **nbn** will supply Fibre TV to Customer in respect of that Eligible Estate; and
- (b) Customer will promptly commence installation and activation activities for the supply of Customer Content to Premises in that Eligible Estate in accordance with clause 5.

4.7 Notwithstanding clause 4.6, if **nbn** accepts an order for Fibre TV in respect of an Eligible Estate, it may subsequently reject the order at any time up until it begins supplying Fibre TV to Customer if **nbn** determines, acting reasonably, that:

- (a) an Acceptance Test conducted under clause 3 has failed; or
- (b) Customer has failed to comply with its Delivery Plan in respect of the Eligible Estate, including by failing to take all steps necessary to install and activate required Customer Equipment.

## 5 Installation and Activation

- 5.1 This clause 5 applies in respect of each Eligible Estate for which **nbn** accepts a Fibre TV order under clause 4.
- 5.2 Customer must, at its own cost, install, activate and test the Head-End Equipment and RF Converter in accordance with:
  - (a) its Delivery Plan, subject to any variations agreed with **nbn** from time to time; and
  - (b) any reasonable directions given by **nbn** from time to time.
- 5.3 Customer must ensure all Customer Equipment is clearly marked as such in accordance with all reasonable directions given by **nbn** from time to time.
- 5.4 **nbn** is not responsible for the supply, installation, operation, maintenance, repair, assurance or support of any Internal Cabling or End User Equipment.

## 6 Operations, Assurance and Maintenance

- 6.1 Following successful installation and activation of Customer Equipment and Fibre TV Infrastructure in respect of an Eligible Estate, and throughout the Term, Customer must:
  - (a) supply Customer Content to each Premises in that Eligible Estate in accordance with its Delivery Plan; and
  - (b) ensure that free to air television content that is ordinarily available in the area is supplied to each Premises in that Eligible Estate on a continuous basis and:
    - i there is no charge to any end user for access to such content; and
    - ii the supply of such content is not conditional upon the acquisition of any other product or service.
- 6.2 Customer must:
  - (a) negotiate with any upstream content supplier that wishes to supply content for inclusion in the Customer Content;
  - (b) not unreasonably refuse a request from an



- upstream content supplier to include content in the Customer Content; and
- (c) not enter into any agreement, arrangement or understanding with an upstream content supplier under which Customer carries content from the upstream content supplier to Premises in any Eligible Estate to the exclusion of any content from another upstream content supplier.
- 6.3 Customer must ensure that Customer Content is only injected into Fibre TV Infrastructure:
- (a) at the NNI-RFo for the Eligible Estate as notified by **nbn**;
- (b) on a channel of 1550 nanometre wavelength capacity;
- (c) in accordance with each technical requirement in Schedule 2 and Annexure 1;
- (d) otherwise in accordance with this Agreement; and
- (e) in accordance with any reasonable directions given by **nbn** from time to time.
- 6.4 Customer must, at its own cost, maintain all Customer Equipment and Customer Platforms in a good, proper, and operable condition and state of repair in accordance with all applicable laws and this Agreement.
- 6.5 Customer must promptly give **nbn** written notice of any damage to any lines, civil works, Customer Equipment, the **nbn**<sup>®</sup> Network or **nbn**<sup>®</sup> Platform, or of any other maintenance issue of which Customer becomes aware.
- 6.6 Customer is responsible for managing all end user interactions regarding any matter in connection with this Agreement, including Customer Content, Fibre TV, Fibre TV Infrastructure, Customer Equipment, Internal Cabling and End User Equipment.
- 6.7 Customer must provide end users with fault reporting mechanisms which are available 24 hours per day, 7 days per week, including at least a nationally available free call or local call number.
- 6.8 If Customer becomes aware of, or suspects the existence of, any fault which is affecting or which has the potential to affect the supply of Customer Content or any other assurance requirement in connection with this Agreement, Customer must promptly (and in every case within two hours of becoming aware of, or suspecting the existence of, the fault) perform remote fault diagnosis and identify whether any fault exists.
- 6.9 If Customer identifies a fault which is affecting, or which has the potential to affect, the supply of Customer Content (including pursuant to clause 6.8), Customer must take the following actions, as applicable:
- (a) in relation to any fault in Customer Equipment or any other matter or circumstance within Customer's control or responsibility, promptly begin, and within 2 Business Days of identification, complete, rectifying the fault;
- (b) in relation to any fault in the Fibre TV Infrastructure, Fibre TV or any other matter or circumstance within **nbn**'s control or responsibility, promptly notify **nbn** and provide **nbn** with a status report for the associated Head End Equipment;
- (c) in relation to any fault with an end user's broadband service, promptly refer affected end users to their broadband access service providers; and
- (d) in relation to any fault in End User Equipment or Internal Cabling, promptly refer affected end users to a suitably qualified and registered technician.
- 6.10 **nbn** will use reasonable endeavours to rectify any fault affecting its supply of Fibre TV to Customer.
- 6.11 Customer must:
- (a) procure access for **nbn** to end users' premises as required by **nbn** in connection with operations, assurance and maintenance of Fibre TV Infrastructure or the **nbn**<sup>®</sup> Network, **nbn**<sup>®</sup> Platform or any other network, platforms, systems, equipment or facilities of **nbn**; and



- (b) provide **nbn** such assistance as:
- i is required by any operations manual provided by **nbn**, as updated from time to time; and
  - ii otherwise reasonably requested by **nbn** in connection with its obligations under clause 6.10.

6.12 **nbn** may interrupt the supply of Fibre TV at any time if **nbn** determines that such interruption is necessary or desirable to rectify a fault in, upgrade, maintain or reconfigure any product or service, the **nbn**<sup>®</sup> Network, **nbn**<sup>®</sup> Platform or any other networks, platforms, systems, equipment or facilities of **nbn**.

6.13 **nbn** will give Customer as much notice of an interruption under clause 6.12 as is reasonably practicable in the circumstances.

- 6.14 Customer must ensure that it has and maintains all resources necessary to comply with this clause 6 in a manner that:
- (a) complies with any service standards notified by **nbn** from time to time; and
  - (b) does not adversely affect the reputation of **nbn**, the **nbn**<sup>®</sup> Network or any **nbn**<sup>®</sup> product or service.

6.15 Unless otherwise notified by **nbn**, Customer must keep **nbn** informed of all fault rectification and assurance activities in connection with this Agreement.

6.16 **nbn** may at any time and at nbn's cost, acting reasonably, conduct, or direct Customer to conduct, operational tests or audits of Customer Equipment and any status reports provided in relation to the Customer Equipment.

6.17 If **nbn** determines that there is any defect or other issue which requires the replacement, repair or reconfiguration of any Customer Equipment, Customer must undertake such replacement, repair or reconfiguration within any timeframe required by **nbn**, acting reasonably.

## 7 Charges

7.1 Subject to the introduction of any new charges

under clause 7.2, **nbn** will supply Fibre TV for a price of \$0.

7.2 If **nbn** reasonably determines that Customer has failed to comply with its obligation to manage end user interactions in accordance with the requirements of any operations manual provided by **nbn** under clause 6.11(b)i, **nbn** may vary this Agreement to introduce a No Fault Found Charge by giving 30 days' written notice to Customer. Any No Fault Found Charge introduced shall be equivalent to the No Fault Found Charge (Truck Roll Required) for NEBS under the WBA SFAA.

7.3 Each party acknowledges, and represents to the other party, that it enters into this Agreement for good and valuable consideration including the other party agreeing to perform the other party's obligations under this Agreement.

## 8 Service levels

8.1 Customer acknowledges that **nbn** will not provide any service levels in connection with the performance of any obligation under this Agreement.

8.2 **nbn** will not provide Customer with any rebates, discounts, credits or other payments or incentives in connection with Fibre TV.

8.3 Customer must record its fault response and rectification performance in connection with its obligations under clauses 6.5 to 6.9 and provide **nbn** with such records or summaries as reasonably requested by **nbn** from time to time.

## 9 Policies and Procedures

9.1 Customer must comply with each **nbn**<sup>®</sup> policy and procedure applicable to Customer's activities in connection with this Agreement, including all the policies outlined in any operations manual provided by **nbn**, as updated from time to time.

9.2 **nbn** will make the applicable policies and procedures available to Customer prior to the commencement of the Agreement.

9.3 Customer acknowledges that **nbn** may need to update policies and procedures from time to



time, including to:

- (a) protect the integrity of the network, systems, equipment or facilities of nbn or any other person which are used in connection with the nbn's network, systems, equipment or facilities;
- (b) ensure the quality of any product or service supplied by the Supplier to the Customer or any other person;
- (c) protect the health or safety of any person or protection of the environment; or
- (d) comply with law.

9.4 nbn will endeavour to provide Customer 30 days' notice before any changes to policies and procedures take effect. Where practicable, in respect of any material changes that may adversely affect Customers, nbn will consult with the Customer before making the changes and will take Customer's feedback into account.

## 10 Protection and safety

10.1 Each party is responsible for the safe and environmentally responsible operation of its network, platforms, systems, equipment and facilities.

10.2 Each party must not cause, and must ensure that:

- (a) acts or omissions of its Personnel do not;
- (b) its networks, platforms, systems, equipment and facilities (and those of its Personnel) do not; and
- (c) in the case of Customer, any Customer Equipment and any Customer Platform does not,

give rise to an Adverse Network Impact.

10.3 Customer must:

- (a) comply, and ensure that its Personnel comply, with all work, health and safety laws and environmental laws;

- (b) not, and ensure that its Personnel do not, at any time, cause **nbn** to be in contravention of any work, health and safety laws or environmental laws;
- (c) ensure that it and its Personnel undertake all work in accordance with all relevant laws and in a manner which does not contribute to any risk to the health or safety of any person,

in connection with its acquisition of Fibre TV and supply of Customer Content.

## 11 Insurance

11.1 Customer must hold appropriate and industry-standard levels of insurances including each Required Insurance throughout the Term.

11.2 Customer must ensure that **nbn** is an insured party in respect of Customer's Required Insurance in respect of public liability.

11.3 Customer must maintain its Required Insurance in respect of professional indemnity for a period of three (3) years after the expiry or termination of this Agreement.

11.4 Customer must ensure, save in respect of its Required Insurance for professional indemnity, that its Insurance Policies include terms whereby the insurer's indemnity applies on an occurrence basis (not on a claims-made basis).

## 12 Warranties

12.1 Throughout the Term, Customer warrants that:

- (a) prior to accessing any Site, it has obtained or will obtain, each Authorisation which is required for Customer to lawfully access the Site;
- (b) prior to injecting any Customer Content into Fibre TV Infrastructure in respect of an Eligible Estate, it has obtained or will obtain, each Authorisation which is required for Customer to lawfully do so;
- (c) all Customer Content has all necessary Authorisations and complies with each condition or requirement of each such Authorisation (including as to copyright, classification, surveillance notification and





any other condition or requirement imposed by any person with a right to do so);

- (d) prior to performing each obligation under this Agreement, it has obtained or will obtain, each Authorisation which is required for Customer to lawfully perform the obligation;
- (e) it will maintain and comply with each Authorisation under clauses 12.1(a) to 12.1(d);
- (f) its Personnel will be suitably qualified and trained and will possess all skills and experience necessary or desirable to facilitate Customer performing its obligations under this Agreement; and
- (g) it will comply with all relevant laws in exercising its rights and performing its obligations under this Agreement.

12.2 Customer must do all things necessary to give effect to each warranty in clause 12.1 at its own cost.

### 13 Confidential Information

13.1 Each party (**recipient**) must keep confidential, and not disclose, any Confidential Information of the other party, except:

- (a) where the recipient has obtained the prior written permission of the other party;
- (b) to the recipient's Personnel, professional advisers, auditors and insurers, provided that it directs such persons to keep confidential all such Confidential Information and, where Customer is the recipient, procures a written undertaking that such persons will keep confidential all such Confidential Information and only use such Confidential Information for the purpose for which it was disclosed by **nbn**; and
- (c) where the recipient is compelled to do so by law, provided that it gives the other party written notice prior to disclosure if permitted.

13.2 The recipient must only use Confidential Information of the other party for the purpose

for which it was disclosed in connection with this Agreement.

13.3 **nbn** may disclose Confidential Information of Customer to any Minister, Department or officer of the Commonwealth Government of Australia or any Government Agency for a legitimate government purpose.

13.4 **nbn** may, on the directions of any Minister, Department or office of the Commonwealth Government of Australia or any Government Agency publish key information in respect of this Agreement including Customer's name, subject matter, term and value of this Agreement.

13.5 Customer must not make any public statement or issue any press release concerning or relating to this Agreement or Customer's relationship with **nbn** unless it has first obtained the written consent of **nbn** to do so, such consent not to be unreasonably withheld.

13.6 **nbn** may require Customer to sign a confidentiality agreement or undertaking in respect of any confidential information of a third party data provider which **nbn** proposes to disclose to Customer.

### 14 Privacy

14.1 Each party must comply with all Privacy Laws in its performance of this Agreement.

14.2 Each party obtain all necessary consents prior to disclosing any Personal Information to the other party in connection with this Agreement, including consents to the other party collecting, using, storing and disclosing such Personal Information for the purposes of this Agreement

14.3 Each party must only use Personal Information disclosed by the other party under this Agreement for the purpose for which it was provided and not any other purpose.

### 15 Data security

Each party must apply reasonable security standards in respect of any data or information which it holds of the other party (including Confidential Information and Personal Information).



## 16 Credit review

- 16.1 At any time, upon providing reasonable notice to Customer, **nbn** may conduct a **Credit Review** as set out in clause 16.2.
- 16.2 A Credit Review is an assessment of data to enable **nbn** to determine whether Customer has good financial standing and creditworthiness. A Credit Review may include, but is not limited to, an investigation of Customer's:
- (a) credit rating;
  - (b) financial statements and credit information; and
  - (c) insurance details, including current and historical statuses.
- 16.3 Customer will allow **nbn** to conduct a Credit Review and will co-operate fully with **nbn** in facilitating this review.

## 17 Intellectual Property Rights

Nothing in this Agreement operates to transfer or assign ownership of Intellectual Property Rights, or confers on either party any right, title or interest in or to, any of the other party's Intellectual Property Rights or Third Party IPR, except as expressly provided under this Agreement.

## 18 Rights and Beneficial Interest

- 18.1 Nothing in this Agreement gives or transfers to Customer (or any other person) any right, title or interest (whether legal, equitable or statutory) in any part of the **nbn**<sup>®</sup> Network, **nbn**<sup>®</sup> Platform, **nbn**'s systems, equipment, facilities or any other tangible or intangible property of **nbn** except to the extent expressly provided for in this Agreement.
- 18.2 Customer must not grant any Security Interest in any Head End Equipment or RF Converter to any person.

## 19 Liability and Indemnities

- 19.1 Except as expressly stated in this Agreement, **nbn** will, to the maximum extent permitted by law, have no liability in connection with this Agreement, whether in contract, tort (including negligence), statute, equity or otherwise.

- 19.2 Customer indemnifies **nbn** and its Personnel (**those indemnified**) from and against any Loss or Claim which any of those indemnified pays, suffers, incurs or is liable for arising out of or in connection with:
- (a) the death or personal injury of any person;
  - (b) loss of, or damage to, any tangible property;
  - (c) any breach of law or infringement of a third party's rights (including Intellectual Property Rights);
  - (d) any failure to collect, use, store or disclose Personal Information in accordance with clause 14;
  - (e) any interference with any **nbn**<sup>®</sup> products or services or their supply;
  - (f) any act or omission of fraud, dishonesty, reckless or wilful misconduct or misrepresentation; and
  - (g) the acquisition of Fibre TV or supply of, or failure to supply, Customer Content,
- to the extent caused or contributed to by any act or omission of Customer or its Personnel.

- 19.3 **nbn** indemnifies Customer and its Personnel (**those indemnified**) from and against any Loss or Claim which any of those indemnified pays, suffers, incurs or is liable for arising out of or in connection with:
- (a) the death or personal injury of any person;
  - (b) loss of, or damage to, any tangible property; and
  - (c) any act or omission of fraud, dishonesty, reckless or wilful misconduct or misrepresentation,
- to the extent caused or contributed to by any act or omission of **nbn** or its Personnel.

- 19.4 To the maximum extent permitted by law, each party excludes any and all liability for any Indirect Loss suffered in connection with this Agreement, whether in contract, tort (including negligence), statute, equity or otherwise.



19.5 To the extent permitted by law, each party's aggregate liability to the other party in any year in respect of any and all Losses under, arising from or in connection with this Agreement, is limited to \$5 million.

## 20 Disputes

20.1 Where a party considers there is a Dispute under this Agreement (**Dispute**), it must, as soon as reasonably practicable, give written notice to the other setting out the existence and nature of the Dispute (**Dispute Notice**).

20.2 The parties must endeavour to resolve any Dispute within 10 Business Days of the date of the Dispute Notice or such other period of time as the parties may agree.

20.3 If the Dispute is not resolved within the period referred to in clause 20.2:

(a) each party will promptly refer the Dispute to their appropriate officers with authority for resolving the Dispute; and

(b) the officers of each party must meet to attempt to resolve the Dispute within a further 10 Business Days or such other period of time as may be agreed.

20.4 If the Dispute is still not resolved within the period referred to in clause 20.3(b), either party may, by notice to the other party, refer the Dispute to mediation, in which case:

(a) the mediation will be undertaken in accordance with the then current Resolution Institute Mediation Rules;

(b) the mediator will be agreed by the parties or, failing agreement within 5 Business Days of the referral, either party may request the mediator be appointed by the Chair of the Resolution Institute;

(c) the parties will endeavour, with the assistance of the mediator, to resolve the Dispute within 30 Business Days of the appointment of the mediator or such other period as the parties may agree;

(d) any mediation meetings and proceedings under this clause 20.4 must be held in Sydney, Australia unless otherwise agreed

by the parties;

(e) the parties will comply with the then current Resolution Institute Mediation Rules and any agreed procedures relating to the proceedings; and

(f) the mediation and all communications during the mediation will be treated as confidential and must be treated as made in the course of compromise and settlement negotiations for the purposes of the applicable rules of evidence and any professional secrecy protections provided by any applicable law.

20.5 If any Dispute which has been referred to mediation under clause 20.4 has not been resolved within 30 Business Days of such referral, either party may, by notice to the other party, refer the Dispute to arbitration, in which case:

(a) the arbitration will be conducted in accordance with the then current Resolution Institute Arbitration Rules;

(b) the arbitrator will be agreed by the parties or, failing agreement within 5 Business Days of a referral to arbitration, either party may request that the arbitrator be appointed by the Chair of the Resolution Institute;

(c) the arbitrator may not be the same person as the mediator;

(d) the arbitration must be held in Sydney, Australia unless otherwise agreed by the parties; and

(e) a decision of the arbitrator will be binding on the parties except in the event of a manifest error or mistake of law.

20.6 Neither party may commence court proceedings in connection with a Dispute under this Agreement unless it has complied with this clause 20, except where:

(a) a party takes action to recover any amount as a debt due pursuant to this Agreement;

(b) the party seeks urgent interlocutory, injunctive or other declaratory relief; or



(c) the Dispute relates to the other party's material non-compliance with this clause 20.

20.7 Each party must continue to perform their respective obligations in accordance with this Agreement pending the resolution of a Dispute in accordance with this clause 20.

20.8 Each party must do all things reasonably necessary for the proper and expeditious conduct of the processes set out in this clause 20.

20.9 Except as otherwise provided under a binding order as to costs or under law:

- (a) each party will bear its own costs in connection with the resolution of the Dispute; and
- (b) the costs of any arbitrators or mediators, or other costs relating to both parties will be shared equally.

## 21 Term

21.1 This Agreement starts on the date both parties have signed this Agreement and expires on 30 June 2027 unless terminated earlier in accordance with this Agreement or extended by agreement of the parties (**Term**).

21.2 From the date both parties have signed this Agreement until eighteen (18) months after that date, the parties will meet each three months (on a date agreed between the parties) to discuss:

- (a) the performance of this Agreement by each party;
- (b) any issues or problems arising out of the operation of this Agreement by either party;
- (c) any outstanding issues identified in relation to this Agreement; and
- (d) the ongoing commercial viability of this Agreement.

21.3 Twenty four (24) months after both parties have signed this Agreement in its original form, **nbn** and Customer will review the terms of this

Agreement.

## 22 Termination

22.1 **nbn** may terminate the supply of Fibre TV in respect of specific Eligible Estates or this Agreement by notice to Customer:

- (a) where **nbn** determines, acting reasonably, that there is a health or safety risk sufficiently serious to warrant such termination;
- (b) where **nbn** determines, acting reasonably, that the supply or continued supply of Fibre TV will unreasonably jeopardise or interfere with the integrity of the **nbn**<sup>®</sup> Network, **nbn**<sup>®</sup> Platform, or any other network, platforms, systems, equipment or facilities owned, controlled or operated by **nbn** or a third party;
- (c) where **nbn** determines, acting reasonably, that Customer no longer has the rights or ability to supply Fibre TV;
- (d) where Customer ceases or fails to successfully supply Customer Content;
- (e) where Customer breaches any obligation under this Agreement which is incapable of remedy or which is capable of remedy, but is not remedied within 14 days of receipt of a written notice from **nbn** specifying the breach and requiring it to be remedied;
- (f) where Customer breaches any of the warranties in clause 12.1, any of the Supply Conditions or its obligation in clause 25.12(b);
- (g) where Customer or any of its Personnel does anything that materially damages or is likely to materially damage the brand or reputation of **nbn** or any Related Body Corporate;
- (h) where Customer fails to obtain or ceases to hold an Authorisation required for Customer to supply Customer Content;
- (i) where a Change of Control or Insolvency Event occurs in relation to Customer; or
- (j) where **nbn** and Customer fail to agree to



the continuation of, or amendment to, the terms of this Agreement pursuant to a review under clause 21.3.

22.2 The events in clauses 22.1(d), 22.1(e) and 22.1(f) will each constitute a material breach of this Agreement.

22.3 If Customer wishes to terminate this Agreement or the supply of Fibre TV to a specific Eligible Estate, it must give written notice to **nbn** and comply with clauses 22.4 to 22.6.

22.4 Upon notice of termination by either party to the other, Customer must provide **nbn** with a proposal for the continued supply of content to all Premises at the affected Eligible Estate(s), which proposal must provide for at least:

(a) identifying any alternative suppliers of content to Premises at the Eligible Estate(s);

(b) the transfer or replacement of all Authorisations required by the alternative supplier (including entry into a Fibre TV agreement or other carriage content agreement with **nbn** if the alternative supplier has not already done so); and

(c) a transition plan to minimise or avoid any interruption of content supply to Premises at the Eligible Estate(s).

22.5 **nbn** may accept or reject, or direct alterations to, a proposal provided under clause 22.4 at its discretion (acting reasonably).

22.6 If **nbn** rejects or directs alterations to a proposal provided under clause 22.4, Customer must submit a revised proposal to **nbn** and clauses 22.4, 22.5 and this clause 22.6 will apply to such a revised proposal.

22.7 A notice from Customer to **nbn** under clause 22.3 is:

(a) only effective after **nbn** has approved a related proposal; and

(b) is subject to the terms and conditions of any approved related proposal,

under clauses 22.5 and 22.6.

22.8 Upon termination or expiry of:

(a) the supply of Fibre TV in respect of specific Eligible Estates; or

(b) this Agreement,

Customer must take all steps necessary to ensure the continued supply of content comprising the Customer Content to all affected Premises in all affected Eligible Estates in accordance with a proposal accepted by **nbn** under clause 22.5, including by transferring to an alternative supplier, to the extent necessary:

(c) each item of Customer Equipment

connected to Fibre TV Infrastructure; and

(d) each Authorisation.

22.9 Customer must comply with all requirements under clause 22.8:

(a) immediately, if more than 2 months' notice of termination has been given; or

(b) within 2 months (or other notice period agreed in writing with **nbn**), if 2 months' or less notice of termination has been given or if this Agreement expires.

22.10 If Customer fails to:

(a) provide a proposal to **nbn** under clause 22.4 which is approved by **nbn** under clause 22.5; or

(b) comply with clause 22.8,

Customer must immediately transfer to **nbn** or its nominee:

(c) each item of Customer Equipment connected to Fibre TV Infrastructure which is affected by the termination or expiry; and

(d) each Authorisation required to supply any content which is affected by the termination or expiry.

22.11 Upon termination or expiry of the supply of Fibre TV in respect of specific Eligible Estates or this Agreement until the successful conclusion of a transfer under clauses 22.8 to 22.10 (as applicable), Customer must:



- (a) not disconnect, disable or otherwise impair the continued operation of any Customer Equipment; and
- (b) to the extent that Customer can do so in accordance with this Agreement and the law, and in accordance with any reasonable directions from **nbn**, continue to supply Customer Content.

22.12 As soon as practicable after expiry or termination of this Agreement, Customer must return, and must ensure that all Customer's Personnel return, to **nbn** all Confidential Information, equipment, records, documents and materials provided by or on behalf of nbn in connection with this Agreement.

22.13 Clauses 11, 13, 14.3, 15, 19, 20, 22.8 – 22.12, this clause 22.13, clauses 25.2, 25.3, 25.14, 26, sections 17.3 and 17.4 of Schedule 3 and any other obligations which are expressed to or, by their nature, survive expiry or termination, will survive expiry or termination of this Agreement and are enforceable at any time at law or in equity.

### 23 Changes to this Agreement and other documents

- 23.1 For the duration of the Term, **nbn** may change this Agreement where **nbn** determines, acting reasonably, that such a change:
- (a) will not have a material adverse impact on Customer, by giving at least 60 Business Days' notice of that change to Customer; or
  - (b) is necessary to comply with any applicable law or required by a Regulatory Event, by giving as much notice as reasonably practicable of that change to Customer.
- 23.2 Prior to making a change under this clause 23, **nbn** must:
- (a) inform Customer of the purpose of the proposed change;
  - (b) give Customer a reasonable opportunity (of not less than 10 Business Days) to provide feedback to **nbn** on the proposed change; and
  - (c) consider any feedback given by Customer

about the proposed change and determine (in **nbn**'s reasonable discretion) whether to vary the proposed change to address Customer's feedback.

### 24 Force Majeure

- 24.1 To the extent that a Force Majeure prevents a party from performing an obligation under this Agreement, the affected party will be excused from performing that obligation.
- 24.2 A party affected by a Force Majeure must:
- (a) as soon as reasonably practicable, notify the other party of the Force Majeure, its impact on the affected party and the steps the affected party is taking or will take to mitigate the effects of the Force Majeure; and
  - (b) use reasonable endeavours to minimise, overcome the impact of, and mitigate any Losses in connection with that Force Majeure.

### 25 General

- 25.1 **Assignment and subcontracting.** Customer must not assign, novate or otherwise transfer any of its rights or obligations under this Agreement without **nbn**'s prior written consent such consent not to be unreasonably withheld. Each party may use subcontractors or other agents to meet any of its obligations or exercise any of its rights under this Agreement, but it remains liable in respect of the performance of those obligations and the exercise of those rights.
- 25.2 **GST.** Unless otherwise specified, any amounts payable under this Agreement are inclusive of all taxes, levies, rates, charges and imposts of any kind, including withholding tax but excluding GST. If any supply under this Agreement is a Taxable Supply, then the party making the supply may, at the same time that an invoice is rendered for the agreed consideration for the Taxable Supply, recover the amount of GST payable on that Taxable Supply, subject to the issue of a valid Tax Invoice. Unless the context indicates otherwise, terms used in this clause which have a defined meaning in the *A New Tax System (Goods and*



*Services Tax) Act 1999* (Cth) have the same meaning as in that Act.

25.3 **Notices.** All notices given under this Agreement by one party to the other party must be sent to the address notified by the other party. Any such notice will be taken to be received by the addressee:

- (a) in the case of delivery by hand, on delivery;
- (b) in the case of prepaid post, on the fifth Business Day after the day of posting;
- (c) in the case of fax, at the time in the place to which it is sent equivalent to the time shown on the transmission confirmation report produced by the fax machine from which it was sent; and
- (d) in the case of email, unless the party sending the email knows or reasonably ought to suspect that the email and the attached communication were not delivered to the addressee's domain, when the email was sent,

but:

- (e) if the notice would otherwise be taken to be received on a day that is not a Business Day or after 5.00 pm, it is deemed to be received at 9.00 am on the next Business Day; and
- (f) if the notice relates to a dispute or potential dispute in connection with this Agreement, it must be given by a method other than email and the notification is taken to be received by the addressee at the time that the other method of notification is taken to have been received.

25.4 **Relationship.** The parties are independent contractors and nothing in this Agreement gives rise to any relationship of agency, partnership, employment or otherwise.

25.5 **Publicity and representations.** Customer must not make any representation or public statement in connection with this Agreement or the supply of Customer Content without approval from **nbn**, not to be unreasonably withheld.

25.6 **Variation.** Except as set out in clause 23, no variation of this Agreement is effective unless made in writing and signed by each party.

25.7 **Costs, expenses and duties.** Except where this Agreement provides otherwise, each party is responsible for its own costs and expenses of negotiating, preparing and executing this Agreement and any other instrument executed under this Agreement and complying with its obligations under this Agreement.

25.8 **Counterparts.** This Agreement may consist of a number of counterparts and, if so, the counterparts taken together constitute one document.

25.9 **Rights cumulative.** The rights of each party under this Agreement are in addition to, and do not exclude or limit, any other rights or remedies provided by law (except where this Agreement provides otherwise).

25.10 **Waiver.** No waiver of a right or remedy under this Agreement is effective unless it is in writing and signed by the party granting it.

25.11 **Entire Agreement.** These Head Terms, Schedules 1 – 3 and Annexure 1 constitute the entire agreement between the parties in connection with their subject matter and supersede all previous agreements or understandings between the parties in connection with the relevant subject matter. No oral explanation or information provided by any party to another affects the meaning or interpretation of this Agreement or constitutes any collateral agreement, warranty or understanding between the parties. For the avoidance of doubt, nothing in this clause is intended to exclude liability for fraud or fraudulent misrepresentation or any other representations which cannot be excluded by law.

25.12 **Further assurances and compliance with law.**

- (a) Except where otherwise provided in this Agreement, each party must promptly do all further acts and execute and deliver all further documents required by law or reasonably requested by the other party (in form and content reasonably satisfactory to



the other party) to give effect to this Agreement.

- (b) Each party must comply with all relevant laws in exercising its rights and performing its obligations under this Agreement.

25.13 **Severability.** Any term of this Agreement which is wholly or partially void or unenforceable will be severed to the extent that it is void or unenforceable and the remainder of this Agreement continues unaffected.

25.14 **Governing Law and Jurisdiction.** This Agreement is governed by the laws having force in New South Wales and each party submits to the exclusive jurisdiction of the courts having jurisdiction in New South Wales.

## 26 Interpretation

26.1 In this Agreement the following rules of interpretation apply unless the contrary intention appears:

- (a) headings are for convenience only and do not affect the interpretation of this Agreement;
- (b) the singular includes the plural and vice versa;
- (c) words that are gender neutral or gender specific include each gender;
- (d) where a word or phrase is given a particular meaning, other parts of speech and grammatical forms of that word or phrase have corresponding meanings;
- (e) a reference to:
  - i a person includes an individual, partnership, joint venture, Government Agency, association, trust, corporation or other body corporate and its agents, successors and permitted assigns;
  - ii a clause, term, party, schedule or attachment in a part of this Agreement is a reference to a clause, term, party, schedule or attachment to the relevant part of this Agreement;
  - iii this Agreement includes all schedules

and attachments to it; and

- iv a statute includes any regulations or other instruments made under it (delegated legislation) and a reference to a statute or delegated legislation or a provision of either includes consolidations, amendments, re-enactments and replacements;
- (f) the words "such as", "including" and "particularly" and similar expressions are not used as, nor are they intended to be, interpreted as words of limitation;
- (g) a law includes a constitutional provision, treaty, decree, convention, statute, regulation, legislative instrument, ordinance, by-law, mandatory code, mandatory standard, mandatory guideline, mandatory directive, order, ordinance, rule, determination, ministerial direction, binding restriction of or determination by any Government Agency, statutory rule, judgment, writ, order, injunction, declaration, rule of common law or equity, or rule of any stock or securities exchange where the relevant party's stocks or securities are listed or quoted and is a reference to that law as amended, consolidated or replaced and includes any regulations and other subordinate instruments made under or in accordance with those laws;
- (h) "reasonable endeavours" or any similar expressions does not require the payment of money or the provision of any financial benefit;
- (i) "reasonably practicable" or any similar expression does not require a party to take action if the cost of taking that action is, on balance, unreasonable in the prevailing circumstances;
- (j) when the day on which something must be done is not a Business Day, that thing must be done on the following Business Day;
- (k) no rule of construction applies to the disadvantage of a party because that party was responsible for the preparation of this





Agreement or any part of it;

- (l) capitalised terms where used in this Agreement have the meanings given to them in Schedule 1; and
- (m) if there is any inconsistency between the terms of this Agreement and any schedule or annexure of this Agreement, then that inconsistency will be resolved by giving precedence to the documents in the following order:
  - i these Head Terms and Schedule 1;
  - ii Schedules 2 and 3; and
  - iii Annexure 1.



## Schedule 1 – Dictionary

**Acceptance Tests** means tests of the operation of installed and activated Customer Equipment and Customer Platforms as specified by **nbn** from time to time or, if **nbn** has not specified any such tests, industry standard tests for such installations and activations.

**Access Seeker Undertaking** means a deed of undertaking that is enforceable by any third party whose authorisation is required for Authorised Persons to obtain access to an **nbn**<sup>®</sup> Facility, in the form provided by **nbn** to Customer from time to time.

**Accessible Location** means an area of an **nbn**<sup>®</sup> Facility that is made available by **nbn** to be accessed by Customer in connection with Specified Access for a permitted purpose under Schedule 3.

**Adverse Network Impact** means conduct which:

- (a) endangers the health or safety of any person;
- (b) damages, threatens, interferes with, prejudices the integrity of, degrades, or results in the deterioration of, the operation or performance of any other party's network, platforms, systems, equipment and facilities;
- (c) causes a nuisance in or while accessing the network, platforms, systems, equipment and facilities of the other party; or
- (d) in the case of Customer, damages, threatens, interferes with, prejudices the integrity of, degrades, or causes the deterioration, operation or performance of:
  - i the **nbn**<sup>®</sup> Network, **nbn**<sup>®</sup> Platform or any other network, platforms, systems, equipment or facilities of **nbn**;
  - ii communications within the **nbn**<sup>®</sup> Network, **nbn**<sup>®</sup> Platform or any other network, platforms, systems, equipment or facilities of **nbn** (including Carriage Services and Content Services provided over any of them);
  - iii the network, platforms, systems, equipment and facilities of any other user of the **nbn**<sup>®</sup>

Network or **nbn**<sup>®</sup> Platform;

- iv the ability of **nbn** to supply products or services to any person; or
- v other property or facilities of any third party.

**Authorisation** means any third party consent, permit, approval, authorisation and licence, including from any Government Agency, owner, landlord, licensor or mortgagee (including each agreement, determination and consent required under heritage or native title laws).

**Authorised Person** means a person who has been approved by **nbn** to access Accessible Locations of an **nbn**<sup>®</sup> Facility on behalf of Customer, who has successfully completed relevant site induction courses and who has taken all steps and fulfilled all conditions required by **nbn** and each relevant third party for access to an **nbn**<sup>®</sup> Facility.

**Business Day** means any day other than a Saturday, Sunday or public holiday in the location where the relevant works or tasks are being carried out.

**Carriage Service Provider** has the meaning given to that term by section 87 of the Telecommunications Act.

**Carrier** has the meaning given to that term by section 7 of the Telecommunications Act.

**Change of Control** means, in relation to a party, a change of the person which Controls the party or, if no entity Controls the party, the assumption of Control of the party by any person.

**Claim** means any and all claims, alleged claims, actions, suits or proceedings by any person of any nature or kind, whether in contract, tort (including negligence) at common law, in equity, under statute or otherwise howsoever arising.

**Confidential Information** means, in relation to a party, all information, know-how, ideas, concepts, technology, marketing, product, operational, financial and other industrial or commercial knowledge and data of a confidential nature (whether in tangible or



intangible form and whether coming into existence before or after the commencement of this Agreement) of the party or any of its Related Bodies Corporate relating to or developed in connection with this Agreement, but Confidential Information does not include:

- (a) information which is or becomes part of the public domain (other than through any breach of this Agreement);
- (b) information rightfully received by the other party from a third person without a duty of confidentiality being owed by the other party to the third person, except where the other party has knowledge that the third person has obtained that information either directly or indirectly as a result of a breach of any duty of confidence owed to the first party;
- (e) information which has been independently developed by the other party; or
- (f) information about Customer's use of Fibre TV or supply of Customer Content (including where that information is generated by **nbn**) that has been aggregated with other information of a similar or related nature, such that Customer cannot be identified by the information or any part of it.

**Content Service Provider** has the meaning given to that term in section 97 of the Telecommunications Act.

**Control** has the meaning given to that term in section 50AA of the Corporations Act.

**Corporations Act** means the *Corporations Act 2001* (Cth).

**Customer Content** means retransmitted free-to-air television broadcasts and may also include:

- (a) other forms of paid or free television broadcast content;
- (b) intercom camera content;
- (c) security camera content; and
- (d) any other content which is capable of being supplied using Fibre TV in accordance with this Agreement, the ITU-T Recommendations listed in Schedule 2 and Annexure 1, and approved by

**nbn** (such approval not to be unreasonably withheld or delayed).

**Customer Equipment** means any equipment that is:

- (a) used by Customer in connection with Fibre TV Infrastructure, Customer's acquisition of Fibre TV or Customer's supply of Customer Content; or
- (b) provided by or on behalf of Customer to any third party for use in connection with Customer's supply of Customer Content,

but excludes all **nbn**<sup>®</sup> Equipment.

**Customer Platform** means all information technology systems and platforms used by or on behalf of Customer in connection with this Agreement which directly or indirectly interact with information technology systems and platforms used by or on behalf of **nbn**.

**Customer Works** means any works undertaken by or on behalf of the Customer in connection with the installation, operation, inspection, testing, maintenance, repair, relocation, replacement or removal of the Customer Equipment in, at, on or around an **nbn**<sup>®</sup> Facility under this Agreement.

**Duct** means, in respect of an Eligible Estate, an underground tubular structure installed, ready to be used, or intended to be used for the installation, operation and maintenance of telecommunications cables and associated telecommunications equipment, which is owned by **nbn** or over which **nbn** is in a position to exercise control.

**Delivery Plan** means a plan developed by Customer for the supply of Customer Content to Premises at an Eligible Estate, which plan must comprise the following minimum information in the forms and to the specificity required by **nbn** from time to time:

- (a) details of the Eligible Estate;
- (b) such evidence as **nbn** may require from time to time that Customer has all Authorisations which it requires to supply Customer Content to Premises at the Eligible Estate;
- (c) a detailed schedule of milestones and timeframes for the delivery of Customer Content to Premises at the Eligible Estate;



(d) drawings, diagrams and technical specifications detailing Customer's proposed solution design for the supply to Customer Content to Premises at the Eligible Estate, including all interconnection and other technical details required for installation and activation of Head-End Equipment, the Optical Combiner and Internal Cabling; and

(e) any other information as may reasonably be requested by **nbn** from time to time.

**Eligible Estate** means a new development of single dwelling units or multi dwelling units or both, which:

- (a) comprises a sufficient number of Premises to satisfy **nbn**'s scale requirements (as amended from time to time) for the offer of Fibre TV Infrastructure to the developer of the new development; and
- (b) satisfies any other criteria adopted by **nbn** from time to time to determine whether it will offer Fibre TV Infrastructure to developers in respect of a new development.

**Emergency** means an imminent actual or potential risk to the safety of persons or property or the integrity of a telecommunications network requiring immediate action to avoid or mitigate any loss, damage or personal injury.

**End User Equipment** means any equipment used by any end user in connection with Fibre TV or Customer Content.

**FAN** means, in respect of an Eligible Estate, a fibre aggregation node site associated with the Eligible Estate, as designated by **nbn** from time to time.

**Fibre TV** has the meaning given to that term in clause 1.1 of the Head Terms.

**Fibre TV Infrastructure** means the elements of the **nbn**<sup>®</sup> Network used by **nbn** to supply Fibre TV.

**Force Majeure** means any event or circumstance that:

- (a) is not within the reasonable control of an affected party, any of its Personnel or any of its Related Bodies Corporate or any of their Personnel;
- (b) the affected party or any of its Related Bodies Corporate or any of their Personnel is not

reasonably able to prevent or overcome by the exercise of reasonable care such as by having a disaster recovery plan in place; and

(c) causes the affected party to fail to perform any of its obligations under this Agreement,

but does not include:

- (d) any event or circumstance that arises as a result of any lack of funds for any reason or any other inability to pay; or
- (e) any event or circumstance that arises as a result of any negligent act or omission of the Affected Party.

**Government Agency** means any court or tribunal of competent jurisdiction or any agency, authority, board, department, government, instrumentality, ministry, official or public or statutory person of the Commonwealth or of any State or Territory of Australia, and any local or municipal government or governmental bodies.

**Head End Equipment** has the meaning given to that term in Schedule 2.

**Head Terms** means clauses 1 to 26 of this Agreement.

**Indirect Loss** means loss of revenue, loss of profit, loss of goodwill, loss of anticipated savings, loss of opportunity, and any other Loss, not arising naturally and according to the usual course of things from the relevant breach, whether or not such Loss may reasonably be supposed to have been in the contemplation of both parties, at the time they made the contract, as the probable result of the relevant breach.

**Insolvency Event** means the occurrence of any one or more of the following events in relation to a party:

- (a) an order is made that it be wound up, declared bankrupt or that a provisional liquidator or receiver or receiver and manager be appointed;
- (b) a liquidator or provisional liquidator is appointed;
- (c) an administrator is appointed to it under sections 436A, 436B or 436C of the Corporations Act;
- (d) a Controller (as defined in section 9 of the



Corporations Act) is appointed to it or any of its assets;

- (e) it enters into an arrangement or composition with one or more of its creditors (in their capacities as creditors) and that arrangement or composition is not terminated within 10 Business Days, or an assignment is made for the benefit of one or more of its creditors (in their capacities as creditors), in each case other than to carry out a reconstruction or amalgamation while solvent;
- (f) it proposes a winding-up, dissolution or reorganisation, moratorium, deed of company arrangement or other administration involving one or more of its creditors (in their capacities as creditors), or it proposes a standstill arrangement or composition with one or more of its creditors (in their capacities as creditors) and that standstill, arrangement or composition is not terminated within 10 Business Days;
- (g) it is insolvent as disclosed in its accounts or otherwise, it states that it is insolvent, it is presumed to be insolvent under an applicable law (including under sections 459C(2) or 585 of the Corporations Act) or otherwise is, or states that it is, unable to pay all its debts as and when they become due and payable;
- (h) it is taken to have failed to comply with a statutory demand as a result of section 459F(1) of the Corporations Act;
- (i) a notice is issued under sections 601AA or 601AB of the Corporations Act and not withdrawn or dismissed within 21 days;
- (j) a writ of execution is levied against it or a material part of its property which is not dismissed within 21 days;
- (k) it ceases to carry on business or threatens to do so; or
- (l) anything occurs under the law of the Commonwealth or any Australian State or Territory which has a substantially similar effect to any of the events set out in the above paragraphs of this definition.

**Intellectual Property Rights** means any patent, copyright, design right, trade name, trade mark,

service mark, domain name right, semiconductor or circuit layout right or any other form of protection of a similar nature to any of these, anywhere in the world (whether registered or not and including applications for any such right).

**Internal Cabling** has the meaning given to that term in Schedule 2.

**Interconnection Site** means, in relation to an Eligible Estate, the location of the NNI-RFo for Fibre TV as offered by **nbn** in connection with that Eligible Estate.

**Loss** means losses, damages, liabilities, charges, expenses, compensation, fine, penalty, payment outgoings or costs and all related costs and expenses (including reasonable legal fees and reasonable costs of investigation, litigation, settlement, judgment, appeal, interest and penalties) of any nature or kind, howsoever it arises and whether it is present or future, fixed or unascertained, actual or contingent.

**MDU** means, in relation to an Eligible Estate, the communications room at a multi-dwelling unit building comprising the Eligible Estate or part of the Eligible Estate.

**NEBS** means the NBN Co Ethernet Bitstream Service supplied by **nbn** to third parties under a WBA and any replacement product.

**nbn<sup>®</sup> Equipment** means any equipment that is owned, operated or controlled by **nbn** (or any Related Body Corporate of **nbn**):

- (a) that is provided by **nbn** (or any Related Body Corporate of **nbn**) to Customer for use as part of, or in connection with, Fibre TV; or
- (b) to which **nbn** (or any Related Body Corporate of **nbn**) permits Customer to access (or on-grant such access to any third party) as part of, or in connection with, Fibre TV, including the NNI-RFo, Fibre TV Infrastructure (including Optical Combiner), RF Splitter and Converter, and UNI-RFe,

but does not include any Internal Cabling.

**nbn<sup>®</sup> Facility** means a FAN, PDH, Pit and/or Duct, as the context requires.

**nbn<sup>®</sup> Network** means, in respect of an Eligible



Estate, **nbn**'s fibre-to-the-premises network serving that Eligible Estate.

**nbn® Platform** means all information technology systems and platforms used by or on behalf of **nbn** in connection with this Agreement which directly or indirectly interact with information technology systems and platforms used by or on behalf of Customer.

**NNI-RFo** has the meaning given to that term in Schedule 2.

**No Fault Found Charge** means a charge in respect of fault rectification activities undertaken by **nbn** in response to a notice by Customer of a fault, if **nbn** determines that no such fault exists.

**No Fault Found Charge (Truck Roll Required)** has the meaning attributed to it in the WBA.

**Notice of Licence** means a written notification from **nbn** to Customer that a request for Specified Access under Schedule 3 is approved and a Facilities Access Licence has been granted.

**PDH** means, in respect of an Eligible Estate, a premises distribution hub which is a facility that houses optical splitters associated with the Eligible Estate, as designated by **nbn** from time to time.

**Personal Information** means:

- (a) 'personal information', having the meaning given to that term in the *Privacy Act 1988* (Cth); and
- (b) any other information (if any) that is subject to the operation of Part 13 of the Telecommunications Act.

**Personnel** means, in relation to a party or third party, that party's officers, employees, agents, contractors, subcontractors, consultants, Related Bodies Corporate and their officers, employees, agents, contractors, subcontractors, consultants, but in the case of Customer and its Related Bodies Corporate, does not include **nbn**, its Personnel, its Related Bodies Corporate and their Personnel.

**Pit** means, in respect of an Eligible Estate, an underground vault not large enough for a person to fully enter and work within that is owned by **nbn** or over which **nbn** is in a position to exercise control.

**Premises** means each of the following where it forms part of a new development of single dwelling units or multi dwelling units or both:

- (a) an addressable location currently used or planned to be used on an on-going basis for residential purposes; and
- (b) any other location specified by **nbn** as a 'Premises' from time to time.

**Privacy Laws** means all laws pertaining to privacy, protection of personal information and protection of information contained in communications, applicable in Australia, as amended from time to time, including:

- (a) the *Privacy Act 1998* (Cth) (including the Australian Privacy Principles); and
- (b) Part 13 of the Telecommunications Act.

**Regulatory Event** means any of the following events:

- (a) a 'Regulatory Event' as defined in the WBA SFAA; or
- (b) the outcome of a dispute under any agreement between **nbn** and any third party, the subject matter of which is the same or similar to the subject matter of this Agreement, if **nbn** determines that the resolution may affect its ability to perform its obligations under this Agreement.

**Related Body Corporate** has the meaning given to that term in section 50 of the Corporations Act.

**Required Insurance** means:

- (a) workers compensation insurance in accordance with applicable law and awards, and insurance against common law liability to a party's Personnel engaged in connection with this Agreement which must, where permitted by law, include an indemnity in favour of the other party in respect of statutory liability to that party's Personnel;
- (b) public liability and product liability insurance as follows:
  - (i) public liability insurance for an amount not less than \$20 million per occurrence; and



(ii) product liability insurance for an amount not less than \$20 million in the annual aggregate; and

(iii) insuring legal liability for:

(A) loss of, destruction of or damage to Tangible Property;

(B) personal injury, sickness, disease or death of any person; and

(C) indirect loss resulting from any of the above circumstances,

under, arising from or in connection with this Agreement;

(c) professional indemnity insurance for an amount not less than \$10 million per claim and in annual aggregate;

(d) motor vehicle third party property damage insurance for not less than \$20 million in respect of motor vehicles used in connection with this Agreement; and

(e) any other insurance required by law,

(together, the **Insurance Policies**)

**RF Converter** has the meaning given to that term in Schedule 2.

**RF Splitter and Converter** has the meaning given to that term in Schedule 2

**Security Interest** means each of:

(a) a "Security Interest" as defined in the *Personal Property Security Act 2009* (Cth);

(b) security for payment of money, performance of obligations or protection against default (including a mortgage, bill of sale, charge, lien, pledge, trust, title retention arrangement, right of set-off and flawed deposit arrangements); and

(c) thing or preferential interest or arrangement of any kind giving a person priority or preference over claims of other persons or creditors with respect to any property or asset,

and includes any agreement to create any of them or allow them to exist.

**Site** means each, and any part, of:

(a) an Eligible Estate;

(b) an Interconnection Site; and

(c) a site associated with an Interconnection Site, on or at which Duct is located.

**Specified Activity** means any of the activities referred to in sections 10 to 16 (inclusive) of the *NBN Companies Act 2011* (Cth).

**Specified Utility** has the meaning given to the term 'Utility' in section 151DA(9) of the *Competition and Consumer Act 2010* (Cth).

**Supply Conditions** has the meaning given to that term in clause 2.2 of the Head Terms.

**Telecommunications Act** means the *Telecommunications Act 1997* (Cth).

**Term** has the meaning given to that term in clause 21 of the Head Terms.

**Third Party IPR** means Intellectual Property Rights of a third party.

**UNI-RFe** has the meaning given to that term in Schedule 2.

**WBA** means any agreement between **nbn** and another person or persons on the same or similar terms as a WBA SFAA.

**WBA SFAA** means the 'Wholesale Broadband Agreement' published on **nbn**'s website as updated by **nbn** from time to time or any replacement to that agreement.

## Schedule 2 - Fibre TV Product Details

- The following network elements must be used, and supplied by the responsible party, to enable the supply of Fibre TV:

Network element	Responsible party
<b>Head End Equipment</b> which is all equipment necessary to capture, process and retransmit content as Customer Content to Premises at an Eligible Estate	Customer
<b>RF Converter</b> which is equipment that converts Customer Content from an electrical signal into a light signal to be injected into the NNI-RFo	Customer
<b>NNI-RFo</b> which is the interface at the injection point of Customer Content into Fibre TV Infrastructure	<b>nbn</b>
<b>Fibre TV Infrastructure</b> between the NNI-RFo and UNI-RFe which includes the Optical Combiner, fibre optic cabling, splitters and associated equipment and lines	<b>nbn</b>
<b>Optical Combiner</b> which combines Customer Content with NEBS	<b>nbn</b>
<b>RF Splitter and Converter</b> which is equipment that splits Customer Content and NEBS and converts Customer Content from a light signal into an electrical signal at the Premises	<b>nbn</b>
<b>UNI-RFe</b> which is the interface and hand-off point for Customer Content from Fibre TV Infrastructure to Internal Cabling at each Premises	<b>nbn</b>
<b>Internal Cabling</b> which is coaxial cabling that carries the electrical form of the Customer Content from the UNI-RFe to an end user-accessible antenna socket in each Premises	Third party*

\* Internal Cabling is a feature of each Premises which Customer is required to use to supply Customer Content under this Agreement. See clauses 6.1 and 6.6 of the Head Terms for further details.

Customer must ensure that Customer Content which it injects into Fibre TV Infrastructure, and which **nbn** carries over Fibre TV Infrastructure, conforms with ITU-T G.984 Standards and other requirements notified by **nbn** from time to time.



## Schedule 3 – Fibre TV Facilities Access

### 1. Introduction

1.1 This Schedule sets out the terms on which Customer may request, and **nbn** will supply, access to **nbn**<sup>®</sup> Facilities in connection with Customer's acquisition of Fibre TV, at no charge.

### 2. Pre-conditions

2.1 **nbn** will only supply facilities access as described in this Schedule to Customer, in respect of a specific Eligible Estate, if:

- (a) **nbn** is supplying or proposing to supply Fibre TV to Customer in respect of that Eligible Estate on the terms of this Agreement;
- (b) Customer requests the facilities access to acquire Fibre TV in respect of that Eligible Estate in accordance with section 4.1 of this Schedule 3;
- (c) **nbn** determines, acting reasonably, that Customer requires the facilities access to acquire Fibre TV in respect of that Eligible Estate;
- (d) **nbn** has the ability (including the availability of space and authorisations from third parties, where relevant) to supply facilities access in respect of that Eligible Estate; and
- (e) Customer has completed all prerequisites to facilities access as notified by **nbn**,

**(Specified Access)**.

2.2 **nbn** will supply Specified Access, and the terms of this Schedule apply, separately in respect of each Eligible Estate.

2.3 Specified Access does not include:

- (a) building entry rights for Customer Equipment in respect of;
- (b) rights to co-locate Customer Equipment in; or
- (c) physical access rights for Customer Personnel or third parties to,

any other **nbn**<sup>®</sup> facilities or third party sites or facilities. Customer acknowledges it must separately acquire all such rights at its own cost to the extent it requires them in connection with Fibre TV and take into account any associated lead-times.

### 3. Locations

3.1 The only **nbn**<sup>®</sup> Facilities to which **nbn** will supply Specified Access to Customer are:

- (a) the FAN associated with the relevant Eligible Estate;
- (b) the Pit associated with the relevant Eligible Estate;
- (c) the PDH associated with the relevant Eligible Estate;
- (d) the Duct associated with the relevant FAN specified in section 3.1(a) of this Schedule 3;
- (e) the Duct associated with the relevant Pit specified in section 3.1(b) of this Schedule 3; or



(f) the Duct associated with the relevant PDH specified in section 3.1(c) of this Schedule 3.

3.2 In respect of each Eligible Estate, **nbn** will determine whether Specified Access will be provided to a FAN, Pit or PDH and, in each case, any associated Duct to which Specified Access will be provided.

#### 4. Ordering process

4.1 The Customer must submit a request for Specified Access as part of its Delivery Plan (**Request**):

- (a) in the form required by **nbn** as described in any operations manual provided by **nbn** or as otherwise described by **nbn**; and
- (b) in accordance with any reasonable requirements set out by **nbn** from time to time.

4.2 **nbn** may reject a Request in its reasonable discretion and will give Customer written notice of such rejection in accordance with clause 4.4 of the Head Terms.

#### 5. Facilities Access Licence

5.1 If **nbn** accepts a Request, **nbn** will, by giving Customer a Notice of Licence, grant to Customer a non-exclusive, non-transferrable licence for Specified Access:

- (a) in respect of the specific **nbn**<sup>®</sup> Facility set out in the Request or such alternative **nbn**<sup>®</sup> Facility as **nbn** may specify;
- (b) for the limited purposes of enabling supply of Fibre TV to Customer as set out in this Agreement;
- (c) subject to Customer complying with a network design notified by **nbn** (and if no network design is notified, subject to Customer complying with the network design set out in the Delivery Plan);
- (d) on and from the date notified by **nbn**;
- (e) until the expiry or termination of the licence under this Agreement;
- (f) subject to Customer, at its cost, obtaining (prior to exercising any Specified Access under the Facilities Access Licence), maintaining and complying with each Authorisation which is necessary (or which **nbn** notifies Customer that **nbn**, acting reasonably considers to be necessary) to enable Customer to lawfully exercise Specified Access rights under the Facilities Access Licence;
- (g) subject to the terms of this Agreement, as amended from time to time;
- (h) subject to such technical requirements that **nbn** considers, acting reasonably, to be necessary for the operation of the **nbn**<sup>®</sup> Facility, as notified by **nbn** from time to time;
- (i) subject to any specific limitations or conditions that **nbn** considers, acting reasonably, to be necessary for the operation of the **nbn**<sup>®</sup> Facility, notified by **nbn** in its Notice of Licence;
- (j) subject to Customer, its Related Bodies Corporate and each of their Personnel complying with all applicable laws (including any applicable regulations, codes, guidelines and standards); and
- (k) subject to Customer, its Related Bodies Corporate and each of their Personnel ensuring that their Specified Access does not prejudice the ability of any other person to:
  - (i) use the **nbn**<sup>®</sup> Facility; or



- (ii) acquire, or enjoy the acquisition of, products or services that are supplied by, or depend on an input from, **nbn**,

**(Facilities Access Licence).**

- 5.2 Customer accepts each Facilities Access Licence granted under section 5.1 of this Schedule 3, including each term and condition of the Facilities Access Licence, upon **nbn**'s Notice of Licence under section 5.1 of this Schedule 3 unless Customer notifies **nbn** to the contrary, in which case:
- (a) Customer must not undertake any Specified Access pursuant to the Facilities Access Licence;
  - (b) the Facilities Access Licence is revoked and of no further effect upon the Customer's notice; and
  - (c) Customer acknowledges that **nbn** may determine that such refusal comprises an event permitting **nbn** to reject a related order for Fibre TV under clause 4.7(b) of the Head Terms.
- 5.3 Customer will, upon request by **nbn** (acting reasonably), provide copies of any or all Authorisations obtained by the Customer.
- 5.4 Customer warrants to **nbn** that throughout the period of each Facilities Access Licence:
- (a) Specified Access under this Agreement is sought for the sole purpose of enabling the Customer to install approved Customer Equipment to supply Customer Content; and
  - (b) Customer complies and will continue to comply with the terms and conditions of this Agreement and the Facilities Access Licence.
- (each a **Licence Condition** in respect of the Facilities Access Licence).
- 5.5 If Customer breaches a Licence Condition in relation to a Facilities Access Licence, **nbn** may, in addition to **nbn**'s other rights, immediately terminate the Facilities Access Licence and terminate any related supply of Fibre TV under clause 22.1(c) of the Head Terms.
- 5.6 Customer must notify **nbn** within 2 Business Days if, at any time during the Facilities Access Licence, Customer no longer complies with any Licence Condition.
- 5.7 Without limiting any other provisions of this Agreement, Customer must, in respect of its performance of this Agreement, each Request and Facilities Access Licence:
- (a) not engage in any activity that is likely to compromise the ability of **nbn** to perform its obligations under this Agreement;
  - (b) comply with, and ensure all its Authorised Persons comply with:
    - (i) all applicable health, safety and environmental laws, rules and standards including as set out in section 12.6 of this Schedule 3;
    - (ii) any applicable Access Seeker Undertaking;
    - (iii) all technical specifications, operations manual, processes, policies, directions, conditions and limitations issued from time to time by **nbn** in accordance with this Agreement; and
    - (iv) all technical specifications, operations manual, processes, policies, directions, conditions and limitations issued from time to time by third parties entitled to issue such technical specifications, operations manual, processes, policies,



directions, conditions and limitations connection with the facilities and sites in respect of which Specified Access is supplied; and

- (c) in respect of all Specified Access ensure that each of its Personnel:
  - (i) are Authorised Persons;
  - (ii) do (or, as applicable, refrain from doing) all things necessary to ensure the Customer complies with this section 5.7; and
  - (iii) themselves comply with the terms of this Agreement.

5.8 Customer must, upon request from **nbn** (acting reasonably), assist **nbn** to assess Customer's compliance with its obligations under sections 5.1, 5.3, 5.4 and 5.7 of this Schedule 3.

## 6. Protection and safety

- 6.1 Customer must comply with any instructions, policies or procedures given by **nbn** to Customer or any of its Personnel from time to time that **nbn** reasonably considers are required to:
- (a) protect the integrity of the network, systems, equipment or facilities of **nbn** or any other person which are used in connection with **nbn's** network, systems, equipment or facilities;
  - (b) ensure the quality of any product or service supplied by **nbn** to the Customer or any other person; or
  - (c) protect the health or safety of any person or protection of the environment.

## 7. Customer Equipment

7.1 Customer must ensure that:

- (a) each item of Customer Equipment installed or used in or at an **nbn**<sup>®</sup> Facility is safe and marked and labelled in accordance with all applicable laws;
- (b) each item of Customer Equipment complies with this Agreement and all applicable laws and has all necessary regulatory approvals;
- (c) no Customer Equipment is put to any uses prohibited by any regulator;
- (d) it obtains **nbn's** approval (not to be unreasonably delayed or withheld) for each type of Customer Equipment installed or used in or at an **nbn**<sup>®</sup> Facility;
- (e) each item of Customer Equipment installed or used in or at an **nbn**<sup>®</sup> Facility complies with each technical requirement notified by **nbn** from time to time;
- (f) Customer Equipment does not cause electromagnetic interference which disrupts, or has the capacity to disrupt, the efficient operation of the networks, systems, equipment and facilities of **nbn** or any other person.

7.2 Except as expressly set out in this Agreement:

- (a) each item of Customer Equipment remains at the Customer's risk at all times; and
- (b) **nbn** accepts no responsibility whatsoever for the safekeeping of the Customer Equipment or any other property of the Customer,

notwithstanding that it may be located in an **nbn**<sup>®</sup> Facility. . For the avoidance of doubt, this clause does not (and is not intended to) override any rights that a party may have pursuant to applicable



law, including the Australian Consumer Law.

## 8. Property rights and beneficial interest in the nbn<sup>®</sup> Facilities

8.1 Nothing in this Agreement gives or transfers to Customer (or any other person) any right, title or interest (whether legal, equitable or statutory) in any part of **nbn**'s network, systems, equipment or facilities except to the extent expressly provided for in this Agreement.

8.2 The rights conferred by **nbn** under each Facilities Access Licence rest in contract only.

8.3 Nothing in any Facilities Access Licence:

- (a) creates any tenancy between **nbn** and Customer; or
- (b) confers upon Customer any right or interest in any **nbn**<sup>®</sup> Facilities which are the subject of the Facilities Access Licence by way of occupation rights (other than the Facilities Access Licence), easements, rights of way or otherwise,

and Customer agrees not to lodge any caveat against the title of any **nbn**<sup>®</sup> Facilities.

8.4 Each Facilities Access Licence which grants rights in relation to any **nbn**<sup>®</sup> Facility is subject to the encumbrances affecting the land described in the certificate of title for such **nbn**<sup>®</sup> Facility and any applicable lease, licence or other tenure document (if applicable) and, except as expressly stated, does not affect or remove the rights of **nbn**, its Personnel and other invitees.

8.5 Notwithstanding any right granted to Customer under this Agreement (including a Facilities Access Licence), **nbn**:

- (a) retains the right to access each of its **nbn**<sup>®</sup> Facilities at any time and for any purpose, including in order to undertake works and to install, maintain, upgrade or remove cables and other telecommunications equipment (or to facilitate other users of the **nbn**<sup>®</sup> Facilities doing any of those things);
- (b) may grant any third party rights which are the same as, or similar to, those granted to Customer under this Agreement and any Facilities Access Licence, including in respect of any portion of the **nbn**<sup>®</sup> Facility to which the Customer is granted a Facilities Access Licence for Specified Access; and
- (c) may, subject to clause 15, terminate the Facilities Access Licence in the event of a sale (or intended sale) or leaseback or any other similar arrangement of the **nbn**<sup>®</sup> Facility to which the Facilities Access Licence applies, which cannot be disputed by Customer.

8.6 Customer must not assign, lease, license, sub-license, share, alienate, part with, or otherwise deal with any Facilities Access Licence or any right or benefit that is made available by **nbn** to the Customer as part of a Facilities Access Licence, or attempt to do any such thing.

## 9. Customer Works generally

9.1 Customer may not begin Customer Works unless and until **nbn** approves the work in writing (which it may do subject to conditions, or decline to do, in its discretion, acting reasonably) and, if applicable, issues any permit to work as required under any operations manual provided by **nbn**.

9.2 Customer is responsible for locating all other utility and Carrier services before commencing any Customer Works and ensuring the Customer Works do not interrupt, interfere or degrade any such services.

9.3 If at any time during the conduct of Customer Works, Customer needs to change any specifics of the Customer Works approved by **nbn**, including the location of any Customer Equipment or pit, due to practical or technical matters not known to the Customer before conducting the Customer Works,



Customer must first seek and obtain **nbn**'s approval of that change (not to be unreasonably withheld or delayed).

9.4 In conducting the Customer Works, Customer must:

- (a) not do anything in or around any **nbn**<sup>®</sup> Facility which in **nbn**'s reasonable opinion is noxious, offensive or a nuisance;
- (b) not do, suffer or permit, anything whatsoever which intentionally or negligently causes actual material loss or damage to the owners or occupiers of any adjoining or neighbouring land to the **nbn**<sup>®</sup> Facility;
- (c) not damage the **nbn**<sup>®</sup> Facility, any equipment or other property that is owned, operated or controlled by **nbn** (or its Related Bodies Corporate) or any third party and located on or near the **nbn**<sup>®</sup> Facility;
- (d) not install any fittings or fixtures in or on the **nbn**<sup>®</sup> Facility, except as expressly provided in this Agreement or as authorised by **nbn** in writing;
- (e) perform its obligations in a diligent and professional manner with due skill and care; and
- (f) not invite, permit or otherwise cause any person who is not an Authorised Person to access any **nbn**<sup>®</sup> Facility.

9.5 **nbn** may at any time request audits or inspections of any Customer Works in relation to compliance with health, safety and environmental requirements under this Agreement (and for any other purpose agreed by the parties) and Customer must co-operate with **nbn** and provide **nbn** with any information and assistance that is reasonably requested by **nbn** to enable it to conduct the audit or inspection.

9.6 If **nbn**, acting reasonably, identifies (whether or not as a result of any inspection or audit under section 9.5 of this Schedule 3) any defects in relation to the Customer Works including:

- (a) any damage to the **nbn**<sup>®</sup> Facilities or the networks, systems, equipment and facilities of **nbn** or any other user of the **nbn**<sup>®</sup> Facility; or
- (b) any non-compliance with the terms of this Agreement,

(except to the extent that any defects are due to an act or omission by **nbn** or any Force Majeure Event), Customer must, at its cost, rectify those defects as soon as possible after receiving notice from **nbn**.

9.7 If Customer fails to comply with its obligations under this Agreement in respect of Customer Works, without limiting any other rights **nbn** may have, **nbn** may require Customer to:

- (a) remove (or procure the removal of) all Customer Equipment installed or altered in connection with the non-compliant Customer Works; and
- (b) reinstate the **nbn**<sup>®</sup> Facility to the same standard, style and condition which existed prior to the non-compliant Customer Works,

in accordance with **nbn**'s directions and any operations manual provided by **nbn**.

9.8 If the Customer fails to comply with section 9.7 of this Schedule 3, **nbn** may undertake the activities described in section 9.7 of this Schedule 3 at the Customer's cost.

## 10. Customer's installation works

10.1 The Customer must only install its Customer Equipment in the **nbn**<sup>®</sup> Facility specified in a Facilities Access Licence:



- (a) in accordance with any reasonable conditions of access specified by **nbn**;
- (b) subject to the reasonable satisfaction of any conditions specified by **nbn** in relation to the proposed installation, as reasonably determined by **nbn**;
- (c) in accordance with any reasonable directions that may be given by **nbn** in relation to the performance of the installation; and
- (d) in accordance with any operations manual provided by **nbn**; and
- (e) within the shorter of 30 Business Days of the date on which the Customer is first granted access by **nbn** to the relevant **nbn**<sup>®</sup> Facility or any shorter period notified by **nbn**.

10.2 Customer must provide each of the following items to **nbn** within 10 Business Days of the Customer completing the installation of Customer Equipment in any **nbn**<sup>®</sup> Facility under this Agreement:

- (a) a written notice issued by or on behalf of Customer which certifies that the Customer Equipment has been installed in accordance with this Agreement;
- (b) as-built drawings, marked up photographs and marked up copies of the approved network design in a format reasonably specified by **nbn**; and
- (c) any other information reasonably requested by **nbn** to enable it to assess whether the Customer Equipment has been installed in accordance with this Agreement.

## 11. Customer's maintenance works

- 11.1 Customer must, at its own cost, maintain and repair all Customer Equipment in a good, proper and safe and operable condition in accordance with all applicable laws and this Agreement.
- 11.2 Customer must give **nbn** written notice of any damage to an **nbn**<sup>®</sup> Facility, cables or equipment of **nbn** or other users of the **nbn**<sup>®</sup> Facility, or other maintenance issues immediately after the Customer becomes aware of it.

## 12. Physical access

- 12.1 If Customer requires physical access to an **nbn**<sup>®</sup> Facility in respect of which **nbn** is supplying Specified Access or a related Site owned, controlled or operated by **nbn**, Customer must submit a request in accordance with this Agreement and any operations manual provided by **nbn**.
- 12.2 Customer can only request and **nbn** will, subject to this Agreement, only provide physical access:
  - (a) in respect of an **nbn**<sup>®</sup> Facility which is a FAN, to Accessible Locations within the FAN;
  - (b) in respect of an **nbn**<sup>®</sup> Facility which is a Pit, to the Pit; and
  - (c) in respect of an **nbn**<sup>®</sup> Facility which is a Duct, to the Duct,to install, operate, maintain, repair and replace Customer Equipment up to the Termination Point (but not to connect the cables to, or terminate the cables on, **nbn**<sup>®</sup> Equipment).
- 12.3 **nbn** will not provide physical access to any PDH.
- 12.4 Customer may only physically access (or permit or allow physical access to) an **nbn**<sup>®</sup> Facility or a related Site owned, controlled or operated by **nbn**:
  - (a) if **nbn** gives Customer a written notice of approval of a request submitted by Customer under section 12.1 of this Schedule 3;
  - (b) at the times and on the basis specified by **nbn**; and



- (c) subject to any other reasonable terms and conditions as set out in **nbn's** notice of approval of the physical access.
- 12.5 Customer must not make, or cause to be made, any visual or audio-visual recordings within or of any **nbn**<sup>®</sup> Facility or a related Site owned, controlled or operated by **nbn** including photographs or videos, without the prior written consent of **nbn** (which may be given or withheld or given with conditions, in **nbn's** discretion).
- 12.6 Without limiting any other provision of this Agreement, Customer must ensure that any of its Authorised Persons exercising any Specified Access rights or otherwise visiting any **nbn**<sup>®</sup> Facilities or a related Site owned, controlled or operated by **nbn**:
- (a) comply with any policies that are notified by **nbn** to Customer from time to time; and
  - (b) comply with all reasonable directions given by **nbn** to Customer or its Personnel, including in connection with:
    - (i) Customer Works;
    - (ii) **nbn's** or Customer's compliance with any applicable law, including without limitation, any applicable occupational health and safety laws, rules, standards and arrangements, and environmental laws and environmental management arrangements; and
    - (iii) where considered necessary by **nbn**, acting reasonably, any other matter arising in connection with this Agreement; and
  - (c) are properly experienced, qualified and skilled to perform any tasks at such **nbn**<sup>®</sup> Facilities and Sites.
- 12.7 **nbn** may (acting reasonably) refuse any person physical access to any **nbn**<sup>®</sup> Facility or related Site owned, controlled or operated by **nbn**, and any third party with rights in a Site at which an **nbn**<sup>®</sup> Facility is located may refuse any person physical access to such Site, including where:
- (a) there is a health or safety risk sufficiently serious to warrant refusal of that access;
  - (b) the access will unreasonably jeopardise or significantly interfere with the integrity of infrastructure, network, equipment, facilities or operations owned or operated by **nbn** or a third party;
  - (c) the access will create a security risk;
  - (d) Customer is in breach of any provision of this Agreement; or
  - (e) the person seeking access:
    - (i) is not appropriately identified in any arrangements which have been made for physical access;
    - (ii) does not produce acceptable photographic identification;
    - (iii) has previously breached any of the requirements under this Agreement or otherwise caused problems for **nbn** or any relevant third party (for example, in relation to violations of safety or operations practices) and such problems have not been resolved to the reasonable satisfaction of **nbn** or the relevant third party; or
    - (iv) has not yet completed any relevant mandatory site induction or prerequisite course or the eligibility period for that induction or course has expired.





### 13. nbn's Interconnection works

13.1 **nbn** will perform the following interconnection works for each instance of Specified Access supplied by **nbn** to a FAN, PDH or Pit:

Interconnection works	Description
<b>Termination Point</b>	<b>nbn</b> physically connects Customer's lead-in cables to, and terminates Customer's lead-in cables on, passive <b>nbn</b> <sup>®</sup> Equipment in the FAN, PDH or Pit (as applicable).
<b>Cross Connect</b>	<b>nbn</b> physically connects Customer's Network to the NNI-RFo via one or more single mode fibre optic cables and intermediate passive <b>nbn</b> <sup>®</sup> Equipment between the point designated by <b>nbn</b> on the passive <b>nbn</b> <sup>®</sup> Equipment at which Customer's lead-in cables are presented and the point designated by <b>nbn</b> on the NNI-RFo.

13.2 **nbn** will not supply the lead-in cables to be terminated and cross-connected pursuant to Specified Access to Pits, FANs and PDHs.

13.3 Customer must, at its own cost, self-supply or separately acquire, install, operate, maintain, repair and replace any lead-in cables in respect of which Specified Access is supplied.

13.4 **nbn** will only supply Specified Access to Pits, FANs and PDHs in relation to, and Customer must only present, lead-in cables comprising the number of fibres determined by **nbn**, up to a maximum of 24 fibres.

13.5 Customer must not present lead-in cables in Pits, FANs and PDHs, and **nbn** will not utilise cables for Cross Connects, other than single-mode fibre cables.

13.6 **nbn** will conduct works necessary to supply interconnection under section 13.1 of this Schedule 3 at times agreed by the parties, acting reasonably and Customer acknowledges that elements of interconnection may be supplied by **nbn** at different times.

13.7 After **nbn** conducts all interconnection works, **nbn** will advise Customer and:

- (a) if requested by Customer, both parties will, at a mutually convenient time, perform a joint inspection of the works and Customer may conduct tests to determine, acting reasonably, whether interconnection is being supplied in accordance with this Schedule; and
- (b) if Customer, acting reasonably, determines that interconnection has not been supplied in accordance with this Schedule, **nbn** will perform any rectification works required to supply interconnection and this section 13.7 will continue to apply until Customer determines, acting reasonably, that Specified Access is being supplied in accordance with this Schedule.

13.8 **nbn** may permit any third party to be present during the performance of interconnection works or testing where such third parties have an interest in the sites and facilities at or in relation to which Specified Access is supplied or is proposed to be supplied.

13.9 Customer must not, and must not invite, permit or cause any third party to:

- (a) undertake or attempt physical access to, or interaction with, any PDH, the **nbn**<sup>®</sup> Network, any **nbn**<sup>®</sup> Equipment;
- (b) conduct or attempt any works within the scope of the interconnection works to be performed by **nbn** under section 13.1 of this Schedule 3;



- (c) connect the Customer Network to the network of any third party within any relevant **nbn**<sup>®</sup> Facility; or
- (d) interfere with, physically access or otherwise affect any **nbn**<sup>®</sup> Equipment or third party property, network or service within, or operating within, an **nbn**<sup>®</sup> Facility.

#### 14. Temporary interruptions

- 14.1 **nbn** may undertake or permit works that affect **nbn**<sup>®</sup> Facilities at any time, including for the purposes of maintaining or upgrading those **nbn**<sup>®</sup> Facilities.
- 14.2 If **nbn** undertakes works in response to an Emergency the parties agree to cooperate and work together reasonably to respond to the Emergency and the Customer must carry out any necessary works in accordance with **nbn**'s directions.
- 14.3 Unless otherwise notified, Customer's physical access to **nbn**<sup>®</sup> Facilities and Sites may be interrupted for the duration of any works that affect **nbn**<sup>®</sup> Facilities.
- 14.4 **nbn** will use reasonable endeavours to minimise any temporary interruption caused by works undertaken that affect **nbn**<sup>®</sup> Facilities, and will give Customer as much prior notice as is reasonably practicable of works that will cause a temporary interruption, except if the works are in response to an Emergency or the directions of a third party.

#### 15. Decommissioning or sale of **nbn**<sup>®</sup> Facilities

- 15.1 **nbn** may permanently decommission or sell (or sell and leaseback) any part or whole of an **nbn**<sup>®</sup> Facility which is the subject of a Facilities Access Licence if **nbn** has given reasonable notice in writing to Customer (**Decommissioning Notice**).
- 15.2 When a **nbn**<sup>®</sup> Facility is decommissioned or sold, **nbn** may elect to offer Customer access to an alternative **nbn**<sup>®</sup> Facility, as set out in the Decommissioning Notice or subsequently agreed by the parties.
- 15.3 All Facilities Access Licences affected by the decommissioning or sale of an **nbn**<sup>®</sup> Facility will be deemed to have been terminated or, if a Facilities Access Licence is granted in relation to an alternative **nbn**<sup>®</sup> Facility, varied to include the details of the alternative **nbn**<sup>®</sup> Facility from the date set out in the Decommissioning Notice or as otherwise agreed.
- 15.4 Subject to any alternative arrangements that might be agreed, including as set out in sections 15.2 and 15.3 of this Schedule 3, if **nbn** decommissions or sells an **nbn**<sup>®</sup> Facility:
  - (a) **nbn** may terminate any related supply of Fibre TV under clause 22.1(c) of the Head Terms; and
  - (b) Customer must, in accordance with clauses 22.4 to 22.11 of the Head Terms, where relevant, undertake any necessary works set out in the Decommissioning Notice to remove or divert Customer Equipment from an **nbn**<sup>®</sup> Facility that is being decommissioned or sold.

#### 16. Grant and termination in respect of an Eligible Estate

- 16.1 **nbn** will only supply Specified Access to Customer from the date notified or agreed under section 5.1(d) of this Schedule 3 until the successful transfer of Customer Equipment and Authorisations under clauses 22.8 to 22.10 of the Head Terms.
- 16.2 Without limiting any other rights **nbn** may have, **nbn** may terminate supply of Specified Access to Customer earlier than specified in section 16.1 of this Schedule 3 by reasonable notice.



- 16.3 On or after termination or expiry of Specified Access, **nbn** may require Customer to remove specified Customer Equipment from an **nbn**<sup>®</sup> Facility by a specified date.
- 16.4 If Customer fails to comply with a requirement to remove specified Customer Equipment from an **nbn**<sup>®</sup> Facility under section 16.3 of this Schedule 3, **nbn** may remove (or procure the removal of) such Customer Equipment.
- 17. General conditions**
- 17.1 If **nbn** or Customer require access to third party sites or facilities for the supply or acquisition of Specified Access (as applicable), **nbn**'s obligation to supply or continue to supply Specified Access is dependent on, and subject to:
- (a) **nbn** having continuing contractual rights to access and use (and allow Customer to access and use) such sites and facilities; and
  - (b) Customer having continuing rights to access and use such sites and facilities.
- 17.2 Customer must sign any Access Seeker Undertaking which **nbn**, acting reasonably, requires Customer to sign before **nbn** will supply Specified Access.
- 17.3 Notifications from **nbn** to Customer in relation to Specified Access may be provided to operational, technical, relationship, or other points of contact with Customer as agreed from time to time or set out in any operations manual provided by **nbn** to Customer from time to time.
- 17.4 Specified Access is not a listed carriage service or a service that facilitates the supply of a listed carriage service for the purposes of section 152AL of the *Competition and Consumer Act 2010* (Cth). The inclusion or supply of the Specified Access under this Agreement published on **nbn**'s Website does not have the effect of making the Specified Access a declared service for the purposes of Part XIC of the *Competition and Consumer Act 2010* (Cth).



Australia's  
broadband  
network

**Execution Page**



# Annexure 1

## Fibre TV Technical Specifications

Customer access to **nbn**'s Fibre TV Infrastructure for injection of Customer Content is provided via a spliced connection at a "meet-me" location agreed for each Eligible Estate on a site by site basis pursuant to clause 4.2(a) of the Head Terms.

### 1. NNI-RFo Interface Parameters

Table 1 details the optical specifications of the NNI-RFo demarcation point.

**Table 1. nbn® NNI-RFo optical interface parameters**

Parameter	Unit	Nominal Value	Range
Operating Wavelength	nm	1550	1550 to 1560
Maximum input Power FAN and Pit-located NNI-RFo	dBm	+21	+19 to +21
Maximum input Power MDU located NNI-RFo	dBm	+13	+8 to +18
Return Loss	dB	> 55	55 to 65
Isolation	dB	> 30	N/A
Maximum Distance Between FAN NNI-RFo and Eligible Estate	Km	16	N/A

Further detail specific to the generic characteristics of PON RF video overlay can be found in ITU-T specifications G.983.3:2001 and G.984.5:2007, each of which Customer must adhere to.

## NNI-RFo feeder ratios

Table 2 provides an indication of the number of NNI-RFo optical feeds that Customer must present at the NNI-RFo depending on the agreed NNI-RFo location and subject to final **nbn** design.

**Table 2. nbn® NNI-RFo Customer feed to Premises ratio**

NNI location	Connector	Optical Power (dB)	Signal to Premises ratio
NNI-RFo at a FAN	splice	+19 to +21	1 feed per ~128 service locations
NNI-RFo at an MDU	splice	+8 to +18	1 feed per ~32 service locations

## 2. UNI-RFe Interface Parameters

Figure 1 details the electrical specifications of the UNI-RFe. This is the point that the Internal Cabling is connected to the RF Splitter and Converter.

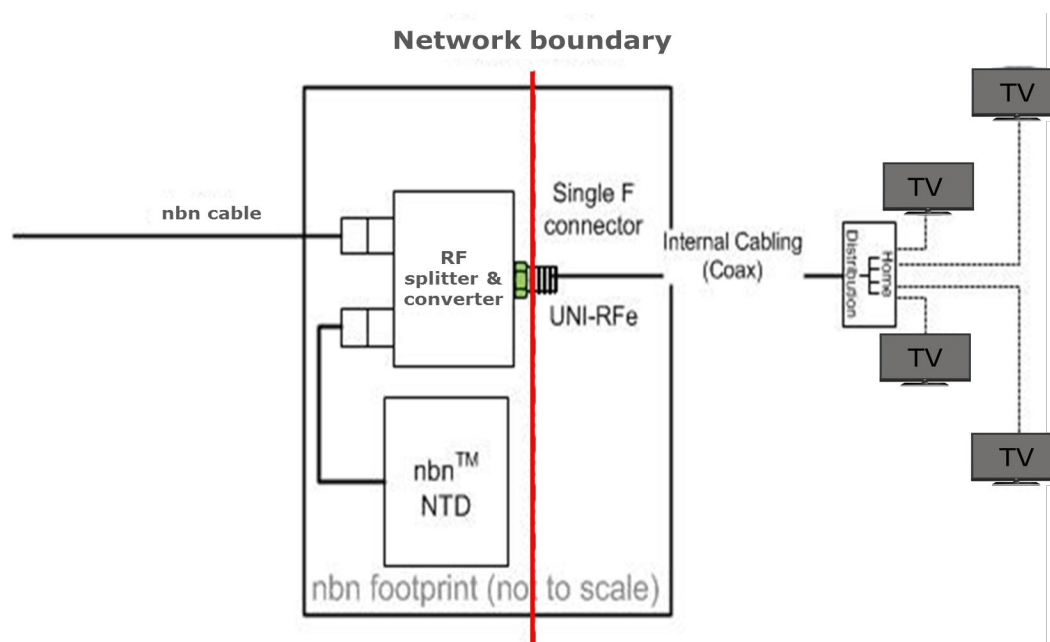

**Figure 1. User Network Interface RF electrical (UNI-RFe)**

\*Note: in accordance with the terms of the Fibre TV Agreement, any end user interactions relating to the components to the right of the UNI-RFe and single F connector are the responsibility of the Customer. **nbn** is not responsible for the supply, installation, operation, maintenance, repair, assurance or support of any such components.

**Table 3. nbn® UNI-RFe electrical interface parameters**



Parameter	Unit	Nominal Value	Range
Bandwidth	Mhz	N/A	50 to 2400
Flatness (deviation over bandwidth)	dB	N/A	+/- 1
Output	dBuV	>80	70 to 85
Output level adjustment	dB	N/A	0 to 18
Output Impedance	Ohm	75	N/A
Output Port type	N/A	Female F connector	N/A
MER (digital signal)	dB	> 30	27 to 39
BER (digital signal)	N/A	< 1.0E-9	N/A
Power consumption	Watt	<= 3	
Working temperature	°C	N/A	-10 to +50
Working relative humidity	%	N/A	5 to 95

### 3. Applicable nbn<sup>®</sup> Optical Loss Parameters

To assist with any Customer Content (RF video overlay) design, this section details the generic unit optical performance parameters using optical components that are approved for use in the Fibre TV Infrastructure. For further information, please refer to the latest issue of "NBN-TE-CTO-177 – Optical Network Performance and Parameters."

#### 3.1 Optical Fibre Loss

**Table 4. nbn<sup>®</sup> optical fibre attenuation**

Wavelength (nm)	Parameter	Average Loss (dB)	Maximum Loss (dB)
1550	dB/Km	0.2	0.22

#### Dispersion

**Table 5. nbn<sup>®</sup> optical fibre dispersion**

Wavelength (nm)	Parameter	Dispersion
1550	(ps/(nm.Km))	≤ 18.0

#### Connector

**Table 6. nbn<sup>®</sup> connector specification**



Type	Parameter	Average Optical Loss	Maximum Optical Loss	Optical Return Loss
SC/APC 8°	dB	0.23	0.3	≥ 65

Note: The loss values above are for 2 mated connectors.